

BALDOR • RELIANCE

Customer information packet

XEFRPM36754

75HP, 1800, 460V, HL365T, TEFC, F1

Specifications

Enclosure	TEFC
Frame	HL365T
Frame Material	Exposed Laminations
Frequency	60.00 Hz
Output @ Frequency	75.000 HP @ 60 HZ
Phase	3
Synchronous Speed @ Frequency	1800 RPM @ 60 HZ
Voltage @ Frequency	460.0 V @ 60 HZ
Agency Approvals	CCSA US NEMA PREMIUM
Auxillary Box	No Auxillary Box
Base Indicator	Rigid
Bearing Grease Type	Polyrex EM (-20F +300F)
Constant Torque Speed Range	1-60
Current @ Voltage	74.000 A @ 460.0 V
Duty Rating	CONT
Feedback Device	NO FEEDBACK
Frame Prefix	HL
Heater Indicator	No Heater
High Voltage Full Load Amps	74.0 a
Insulation Class	H
KVA Code	G
Motor Standards	NEMA
Mounting Arrangement	F1
Product Family	Fan - Centrifugal
Pulley End Bearing Type	Ball
Pulley Face Code	Standard
Service Factor	1.15
Shaft Diameter	2.374 IN
Shaft Ground Indicator	No Shaft Grounding
Shaft Rotation	Reversible
Speed	1800 rpm

Part detail

Revision	G
Type	AC
Mech. spec.	
Base	
Status	PRD/A
Elec. spec.	LS7023A
Layout	619706-001
Eff. date	04-23-2019
CD Diagram	422927-001
Poles	04
Leads	
Proprietary	False
Created date	06-03-2016

Thermal Device - Bearing

None

Thermal Device - Winding

Normally Closed Thermostat

Nameplate

000613007QF

	DUTY	HP	RPM	AMPS	VOLTS	HZ					
	CONT	75	1800	74	460	60					
CAT.NO.	XEFRPM36754		SPEC. NO.		H36-A000-0002						
SER.NO.			FRAME SIZE		HL365T	TYPE PSM					
AMB.	40	S.F.	1.15	ENCL.	TEFC	PH	3	DESIGN	B	CODE	G
NEMA NOM. EFF	97.3		GUARANTEED EFFICIENCY		96.7	POWER FACTOR		99.2	INSUL. CLASS		H
D.E. BRG.	75BC02J30X		O.D.E. BRG.		55BC02J30X						
VPWM INVERTER DUTY @1.0SF	CHP HZ	60-90		CT HZ	1-60		VT HZ	0-60			
	XT										

000692000VY

MEAS OPEN CIRCUIT VOLTAGE

IS VOLTS AT RPM.

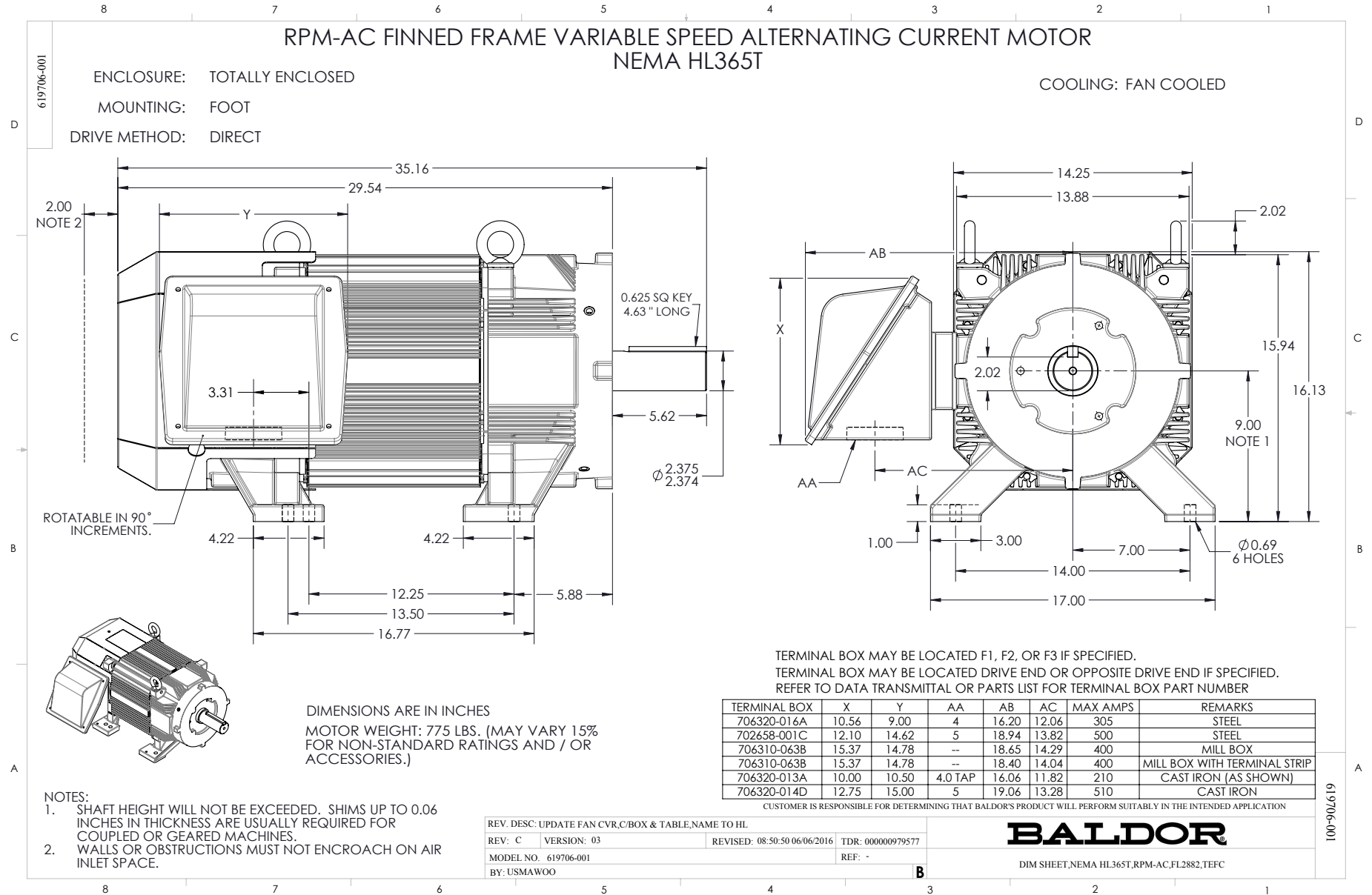

422927-001

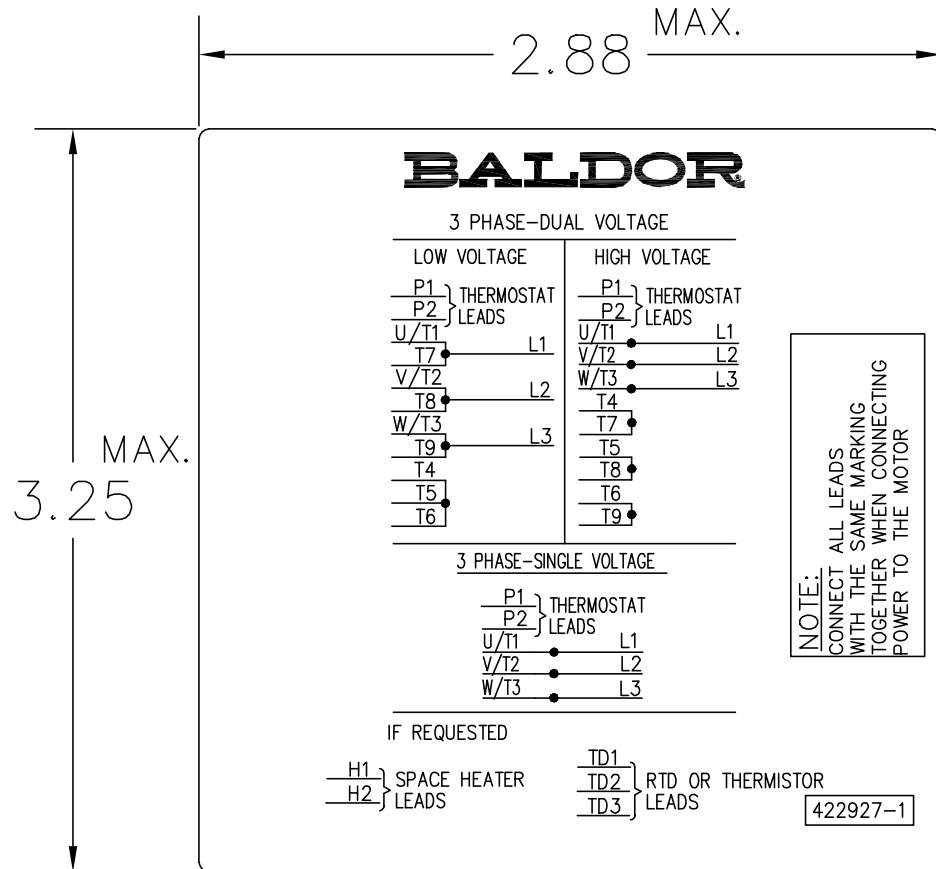

NOTE:
DATA TO BE SIZED
SO THAT IT FITS INTO
MATERIAL DECAL
DIMENSIONS. MAKE
LETTERS & NUMBERS
AS LARGE AS POSSIBLE.

MATERIAL: CERAMATIC DGF-P4
PERMA GRIP ADHESIVE

ALL LETTERS, NUMBERS
AND LINES TO BE BLACK
ON WHITE BACKGROUND.

422927-001

REV. DESC: CHANGE BACKGROUND COLOR FROM GOLD TO WHITE		
REV. LTR: B	VERSION: 02	TDR: 00000788708
FILE: \RGG\00000\203	REVISED: 08:09:29 03/04/2013	
MTL: -	BY: RGGWT	

BALDOR

EXTERNAL CONNECTION LABEL

SH 1 of 1